



- **Standard GSM/3G phone**
- **External Antenna with long cable**
- **Robust housing, constructed of stainless steel**
- **Vandal resistant handset and armored cord**
- **Wall mounting, simple installation**
- **Weather proof protection: up to IP65**
- **Programmable for Auto dial, easy to operate**
- **Wall mounting, simple installation**
- **Supplied with 12V DC Power Supply**
- **CE, FCC compliant**

The Handset Telephone is designed to meet the needs of client who experience loss through vandalism. Ideal for parking lots, prisons, railway/metro platforms, hospitals, police stations, ATM machines, stadiums, outside building etc.

Housed in stainless steel box and manufactured to a high standard, these telephones offer increased resistance to vandalism, and ensure that the primary function of communications is maintained at all times.

Extremely easy to install. The cable entrance is on the back of the phone to prevent from artificial damage, while the keypad is weather and vandal resistant.

GSM/3G

GSM/3G connection offers wireless communications to provide a completely standalone telephone installation. The GSM phone greatly reduces installations costs by eliminating running wires.

GSM TECHNICAL SPECIFICATIONS

Time Out.

Enforces a fixed call maximum time limit to 6-8 minutes from off-hook. Programmable

Power supply

AC Adaptor 240-110V AC to 12VDC
Solar power with internal battery

GSM Bands

Quad-band GSM

Remote programming

Auto-dial numbers, time-out etc. can be programmed

Configuration

Remotely programmable via SMS

Remote monitoring

Remote health-check and fault reporting via SMS

OPTIONS

- Rechargeable battery
- Customized length of external antenna and cable

TECHNICAL SPECIFICATIONS

Casing Material

Brushed stainless steel body
Colors: RED, YELLOW, GREY

Handset Material

ABS material handset with stainless steel spiral cord.

Keypad optional

Hotline Phone without keypad

Temperature

Operating: -30°C to +65°C

Storing: -40°C to +75°C

Weather Resistance

IP65

Ringing Tone

Shrill warble tone 80 dBA @ 1 metre typical

Hook switch

Electronic / magnetic with no visible moving parts

M.T.B.F.

Calculated to have an M.T.B.F. in excess of 50,000 hours using

Weight

Up to 3 kg depending on option

PACKAGE

Unit size: 240 *100 *106 (mm)

Carton size: 340 *235 *165 (mm)

Packaging materials: pearl cotton, carton

Gross weight: 3.5KG

Net weight: 2.7KG

DIMENSIONS

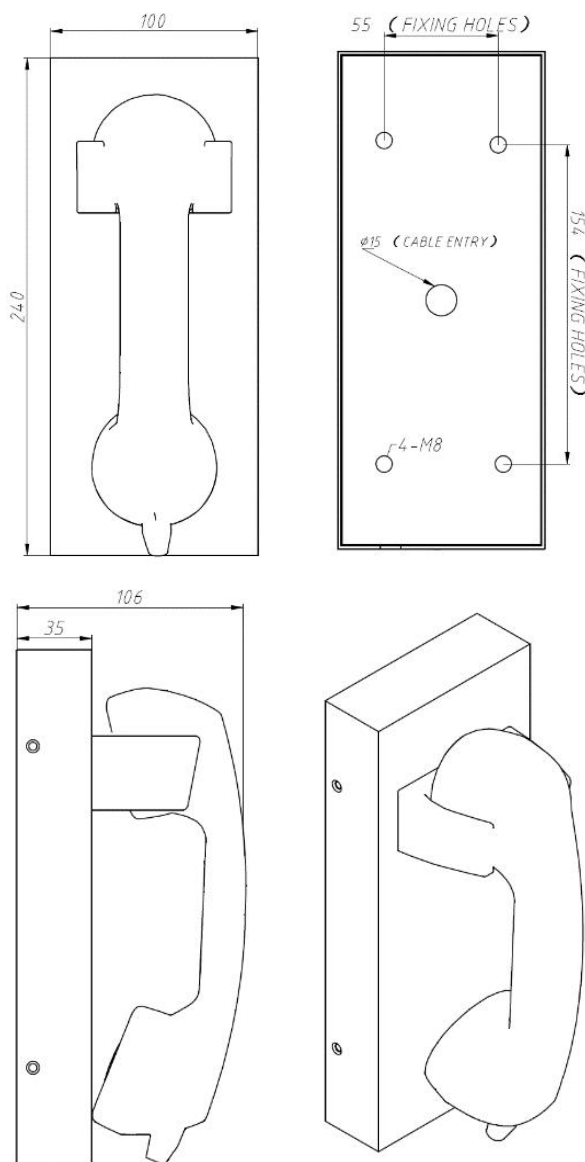

(Measured in mm)

APPROVALS



This mark indicates compliance with the:
Radio & Telecommunications Terminal Equipment
Directive
2004/108/EC



This mark indicates compliance with the:
FCC Part 15 Subpart B Class B